

# Technical User Manual

## JDCR-LCPA

---

*Multi-Band Consumer Repeater*



JDTECK INC.  
215 Celebration Place,  
Suite 180-190  
Kissimmee FL 34747  
sales@jdteck.com  
1-866-4-JDTECK



Record your repeater settings here.

Downlink			Uplink		
DIP	Modulation	Value	DIP	Modulation	Value
1	LTE A+B	<input type="text"/>	6	700 A+B	<input type="text"/>
2	LTE C	<input type="text"/>	7	700 C	<input type="text"/>
3	CELLULAR	<input type="text"/>	8	CELLUAR	<input type="text"/>
4	PCS	<input type="text"/>	9	PCS	<input type="text"/>
5	AWS	<input type="text"/>	10	AWS	<input type="text"/>
Total dB Attenuated		.....	Total dB Attenuated		.....
Adjusted By: _____			Date:	...../...../.....	

Record your repeater settings here.

Downlink			Uplink		
DIP	Modulation	Value	DIP	Modulation	Value
1	LTE A+B	<input type="text"/>	6	700 A+B	<input type="text"/>
2	LTE C	<input type="text"/>	7	700 C	<input type="text"/>
3	CELLULAR	<input type="text"/>	8	CELLUAR	<input type="text"/>
4	PCS	<input type="text"/>	9	PCS	<input type="text"/>
5	AWS	<input type="text"/>	10	AWS	<input type="text"/>
Total dB Attenuated		.....	Total dB Attenuated		.....
Adjusted By: _____			Date:	...../...../.....	

### Terminology

### Meaning

AGC	Automatic Gain Control
BTS	Base Transmitting Station (Cell Tower)
CDMA	Code Division Multiple Access
dB	Decibel – (A unit of measure for signal strength)
DAS	Distributed Antenna System.
DL	Downlink (Communication channel from cell tower to mobile device)
Donor	Outdoor Antenna (Antenna that donates an input signal)
GSM	Global System for Mobile Communications
iDEN	Integrated Digital Enhanced Network
LCD	Liquid Crystal Display
LED	Light Emitting Diode
LTE	Long Term Evolution
MS	Mobile Station
PCS	Personal Communication System
RF	Radio Frequency
UL	Uplink (Communication channel from mobile device to cell tower)

### User Warnings – **MUST READ!**



1. This repeater must **ONLY** be used for the purpose it was intended for. Making any alternations to the design layout without first consulting with a trained technician can result in interference to the operator's network and liability by the end user.



2. Please read this entire manual carefully before using this product!



3. Only the power supply that came with the repeater should be used at all times. It is highly recommended that the repeater is grounded and lightning protection used.



4. Do not attempt to open any part of the repeater. This will void the warranty and can cause an electric shock. Electrostatic can also cause damage to the internal components.



5. Please keep away from any heating-equipment, because the repeater will dissipate heat when working. Do not cover the repeater with anything that influences heat-dissipation.



6. Do not place or mount the repeater in a location that is exposed to the elements. This will void the warranty and can cause an electric shock.

## 1. Preface

Personal mobile communication is now part of daily life and persons have come to expect a robust network that meets their increased demand for an always-on network that provides seamless coverage and unlimited bandwidth at high speeds. Cellular repeaters are an integral part of achieving this goal.

A cellular tower in a non-metro environment typically supports a large capacity of users but is affected by a relatively small coverage footprint. Therefore, the average number of users who can access it is limited and a large amount of channel resources go unused. The best way of solving this problem is to use repeaters to extend the BTS coverage to fully utilize the telecommunication resources. Hence cellular repeaters are no longer considered as peripheral devices to cover blind areas in the network but as part of the core network itself. Extending coverage and maximizing the available network resources and revenue growth for the operator.

The complete coverage approach is not only a prerequisite for a high quality mobile cellular network, but also a factor that attracts users. From this point of view, a network operator should first consider providing a radio network architecture with complete coverage in mind. This includes seamless coverage in urban and residential areas as the first step. Cellular repeaters successfully aid in accomplishing this.

With this in mind, JDTECK has focused on successfully developing advanced repeaters that are applicable to any mobile network and indoor distributed antenna system (DAS). Repeaters are available to support any technology or frequency used today.

Because a large amount of BTS or Node B devices are deployed in densely populated urban areas, there is usually no large blind area. Repeaters are simply used to cover small blind spots and provide signal coverage inside buildings or sub-ground locations. Typically, radio frequency (RF) repeaters are used when optical fibers are not available in buildings or when using a fiber solution is not cost effective.

Since the number of repeaters on a cellular network usually increases with the number of buildings to be covered in a specific sector, multiple repeaters may end up feeding from one BTS or Node B. In view of this, the design of the DAS is extremely important to maintain an acceptable noise floor and thus achieve seamless integration to the macro network especially in densely populated areas.

Repeaters adopt an integrated module concept. It is compact in structure and combines the RF module and the monitoring mode in one unit. Owing to its high selectivity, stability and reliability, repeaters are widely applied to indoor signal distribution where signals are shielded due to the various materials used in building construction.

## 6. Specifications.

Electrical Specification		Uplink	Downlink
Frequency Range	LTE(A&B)	698~716 MHz	728~746 MHz
	LTE (C)	776~787MHz	746~757 MHz
	CELLULAR	824~849 MHz	869~894MHz
	PCS	1850~1910 MHz	1930~1990MHz
	AWS	1710~1755 MHz	2110~2155 MHz
Max .Gain	JD65-LCPA-10	50±2dB	50±2dB
	JD65-LCPA-17	45±2dB	45±2dB
Max .Output Power	JD65-LCPA-10	18±2dBm	-10±2dBm
	JD65-LCPA-17	18±2dBm	-10±2dBm
Band width		Wide Band	
Manual Gain Control		≥ 31dB	
Intermodulation Products	9KHz~1GHz	≤ -20dBm	≤ -20dBm
	1GHz~12.75GHz	≤ -20dBm	≤ -20dBm
Spurious Emission	9KHz~1GHz	≤ -36dBm	
	1GHz~12.75GHz	≤ -30dBm	
Gain Flatness		CELLULAR & LTE & AWS ≤ 8dB / PCS ≤ 10dB	
Noise Figure		≤ 9dB	
VSWR		≤ 3	
Group Delay		≤ 1.0μs	
Frequency stability		≤ 0.01ppm	
Variable Gain		The UL gain automatically attenuates at the same dB level as the DL gain when the ALC is activated, however the DL gain does not change if UL automatically attenuates.	
Uplink Inactivity		Shuts down after ≥ 295S of the noise level ≥ -70dB	
OSCILLATION DETECTION	Detection time @1st	≤ 300mS	≤ 1000mS
	Restart time @ 2nd	≥ 60S	≥ 60S
	Restart times	≤ 5	≤ 5
<b>LED Alarm</b>		<b>Standard</b>	
Power LED		Power Indicator	
ALC LED		Orange @ ALC 1~5dB, Red @ ALC 15dB~20dB	
<b>Mechanical Specifications</b>		<b>Standard</b>	
I/O Port		N-Female	
Impedance		50 ohm	
Operating Temperature		-25°C~+55°C	
Environment Conditions		IP40	
Dimensions		250 x 250 x 52mm / 9.8 x 9.8 x 2 Inches	
Weight		≤ 5.0Kg / 11Lbs	
Power Supply		Input AC90~264V,output DC12V / 5A	
FCC ID		SQX-JDCR-LCPA	

#### 4.4 Optional Booster Antenna Kitting ~ Con't.

**Option 13:** 5dBi Omni Antenna with 5 meters 400 Series Coax Cable (N-Male Connectors)

Frequency	698~746	746~787	824~894	1850~1990	1710~2170
Antenna Gain (dBi)	5	5	5	5	5
Cable Loss (dB)	1	1	1	1.5	1.5
Final Gain Less	4	4	4	3.5	3.5

**Option 14:** 3dBi Omni Ceiling Antenna with 5 meters 400 Series Coax Cable (N-Male Connectors)

Frequency	698~746	746~787	824~894	1850~1990	1710~2170
Antenna Gain (dBi)	3	3	3	3	3
Cable Loss (dB)	1	1	1	1.5	1.5
Final Gain Less	2	2	2	1.5	1.5

#### 5. FCC Statement

##### 1. FCC RF Exposure Statement

This equipment complies with FCC radiation exposure limits set forth for an uncontrolled environment. End users must follow the specific operating instruction for satisfying RF exposure compliance. This transmitter must not be co-located or operating in conjunction with any other antenna or transmitter.

##### 2. FCC Warning

**This is a CONSUMER device.**

**BEFORE USE**, you **MUST REGISTER THIS DEVICE** with your wireless provider and have your provider's consent. Most wireless providers consent to the use of signal boosters. Some providers may not consent to the use of this device on their network. If you are unsure, contact your provider.

You **MUST** operate this device with approved antenna and cables as specified by the manufacturer. Antennas **MUST** be installed at least 20cm (8 inches) from any person.

You **MUST** cease operating this device immediately if requested by the FCC or a licensed wireless service provider.

**WARNING.** E911 location information may not be provided or may be inaccurate for calls served by using the device.

This device may be operated **ONLY** in a fixed location for in-building usage.

**Warning:** The Inside Antennas for fixed installations must have 6 feet of separation distance from all active users.

**Warning:** The Outdoor Antennas for fixed installations must be installed no higher than 10 meters above ground.



Figure 1 shows the applications of the repeaters.

## 2. Introduction

This full duplex mobile communications repeater from JDTECK is the perfect solution for providing a wireless improvement in the cellular reception of a large home, office building, restaurant, VIP Room, or apartment in the quickest time possible.

It is designed to improve the call quality of an area by receiving, amplifying, filtering and re-transmitting the signals from the base station into a specified area via a distributed antenna system (DAS) or distributed antenna grid.

To maintain safe and specific output signal levels, this repeater has built-in signal oscillation detection circuits with color changing LEDs to indicate its environmental status. The Alarm LEDs located on the front of the unit (Downlink Alarm & Uplink Alarm) will change color from green to amber or red, (depending on the intensity) if the system detects signal oscillation in either band, or if the input signal is beyond a safe limit so as to avoid interference to the cellular network, the repeater will indicate this.

This repeater also has an automatic gain control (AGC) feature which will reduce the output power of the repeater if oscillation is detected. This range can vary from 15-20dB depending on the model of your repeater. If the reduction in gain needed to take the unit out of alarm exceeds the range of the AGC, then the end user can make use of yet another feature of this repeater called manual gain control (MGC). This allows the end user to further reduce the output gain of the repeater by using the DIP switches on the front of the unit to manually attenuate (reduce) the repeater's output gain of either the uplink or downlink individually. This repeater is also equipped with an uplink sleep feature. It is activated after the repeater detects more than 5 mins of voice or data inactivity through the DAS.

JDTECK's repeaters also feature a Network Safe / MUTE feature that automatically shuts-down the transmission side of the repeater to protect the cellular network if no adjustments are made to eliminate alarm readings on the repeater's LEDs. You will want to make sure the LEDs remain green at all times for optimum system performance.

The main cause of signal oscillation is when any of the indoor antennas are too close in proximity to the outdoor antenna on the roof.

Alarm LED status chart and recommended action:

**Green** - System functioning well.

**Green / Slow Consistent Flash** – Uplink sleep mode activated. (Normal)

**Amber** - Mild detection of oscillation. (Add attenuation)

**Red** - Strong signal oscillation. (Add attenuation)

**Off** – Repeater is not transmitting / MUTE. (Add attenuation & cycle power)

## 4.3 Optional Booster Antenna Kitting ~ Con't.

**Option 7:** 5dBi Omni Antenna with 10 meters 400 Series Coax Cable (N-Male Connectors)

Frequency	698~746	746~787	824~894	1850~1990	1710~2170
Antenna Gain (dBi)	5	5	5	5	5
Cable Loss (dB)	1.3	1.3	1.3	2	2
Final Gain Less	3.7	3.7	3.7	3	3

**Option 8:** 5dBi Omni Antenna with 10 meters 5D-FB Coax Cable (N-Male Connectors)

Frequency	698~746	746~787	824~894	1850~1990	1710~2170
Antenna Gain (dBi)	5	5	5	5	5
Cable Loss (dB)	1.7	1.7	1.7	2.7	2.7
Final Gain Less	3.3	3.3	3.3	2.3	2.3

**Option 9:** 3dBi Omni Ceiling Antenna with 10 meters 400 Series Coax Cable (N-Male Connectors)

Frequency	698~746	746~787	824~894	1850~1990	1710~2170
Antenna Gain (dBi)	3	3	3	3	3
Cable Loss (dB)	1.3	1.3	1.3	2	2
Final Gain Less	1.7	1.7	1.7	1	1

**Option 10:** 3dBi Omni Ceiling Antenna with 10 meters 5D-FB Coax Cable (N-Male Connectors)

Frequency	698~746	746~787	824~894	1850~1990	1710~2170
Antenna Gain (dBi)	3	3	3	3	3
Cable Loss (dB)	1.7	1.7	1.7	2.7	2.7
Final Gain Less	1.3	1.3	1.3	0.3	0.3

**Option 11:** 10dBi Log Periodic Antenna with 5 meters 400 Series Coax Cable (N-Male Connectors)

Frequency	698~746	746~787	824~894	1850~1990	1710~2170
Antenna Gain (dBi)	10	10	10	10	10
Cable Loss (dB)	1	1	1	1.5	1.5
Final Gain Less	9	9	9	8.5	8.5

**Option 12:** 8dBi Indoor Panel Antenna with 5 meters 400 Series Coax Cable (N-Male Connectors)

Frequency	698~746	746~787	824~894	1850~1990	1710~2170
Antenna Gain (dBi)	10	10	10	10	10
Cable Loss (dB)	1	1	1	1.5	1.5
Final Gain Less	9	9	9	8.5	8.5

## 4.2 Optional Booster Antenna Kitting ~ Con't.

**B:** The Indoor Antenna kit. There are 14 options with different type of antennas or variable cable length.

**Option 1:** 10dBi Log Periodic Antenna with 20 meters 5D-FB Coax Cable (N-Male Connectors)

Frequency	698~746	746~787	824~894	1850~1990	1710~2170
Antenna Gain (dBi)	10	10	10	10	10
Cable Loss (dB)	3.4	3.4	3.4	5.4	5.4
Final Gain Less	6.6	6.6	6.6	4.6	4.6

**Option 2:** 10dBi Indoor Panel Antenna with 20 meters 400 Series Coax Cable (N-Male Connectors)

Frequency	698~746	746~787	824~894	1850~1990	1710~2170
Antenna Gain (dBi)	10	10	10	10	10
Cable Loss (dB)	2.6	2.6	2.6	4	4
Final Gain Less	7.4	7.4	7.4	6	6

**Option 3:** 8dBi Indoor Panel Antenna with 20 meters 400 Series Coax Cable (N-Male Connectors)

Frequency	698~746	746~787	824~894	1850~1990	1710~2170
Antenna Gain (dBi)	8	8	8	8	8
Cable Loss (dB)	2.6	2.6	2.6	4	4
Final Gain Less	5.4	5.4	5.4	4	4

**Option 4:** 10dBi Log Periodic Antenna with 10 meters 5D-FB Coax Cable (N-Male Connectors)

Frequency	698~746	746~787	824~894	1850~1990	1710~2170
Antenna Gain (dBi)	10	10	10	10	10
Cable Loss (dB)	1.7	1.7	1.7	2.7	2.7
Final Gain Less	8.3	8.3	8.3	7.3	7.3

**Option 5:** 10dBi Indoor Panel Antenna with 10 meters 400 Series Coax Cable (N-Male Connectors)

Frequency	698~746	746~787	824~894	1850~1990	1710~2170
Antenna Gain (dBi)	10	10	10	10	10
Cable Loss (dB)	1.3	1.3	1.3	2	2
Final Gain Less	8.7	8.7	8.7	8	8

**Option 6:** 8dBi Indoor Panel Antenna with 10 meters 400 Series Coax Cable (N-Male Connectors)

Frequency	698~746	746~787	824~894	1850~1990	1710~2170
Antenna Gain (dBi)	8	8	8	8	8
Cable Loss (dB)	1.3	1.3	1.3	2	2
Final Gain Less	6.7	6.7	6.7	6	6

## Features & Functions

- ✓ Sleek attractive housing.
- ✓ LED indicators to monitor environmental status.
- ✓ Supports all technologies including GSM, WCDMA, UMTS & LTE.
- ✓ Low power consumption.
- ✓ ALC function. (Auto Limit Control – will not exceed max rated power)
- ✓ AGC function. (Automatic Gain Control)
- ✓ MGC function. (Manual Gain Control)
- ✓ MUTE function. (Shuts down if no change in environmental conditions)
- ✓ UL SLEEP function. (UL circuit shut down after 5 mins of inactivity)
- ✓ Heat Sink. Cooling fins to dissipate heat quickly and efficiently

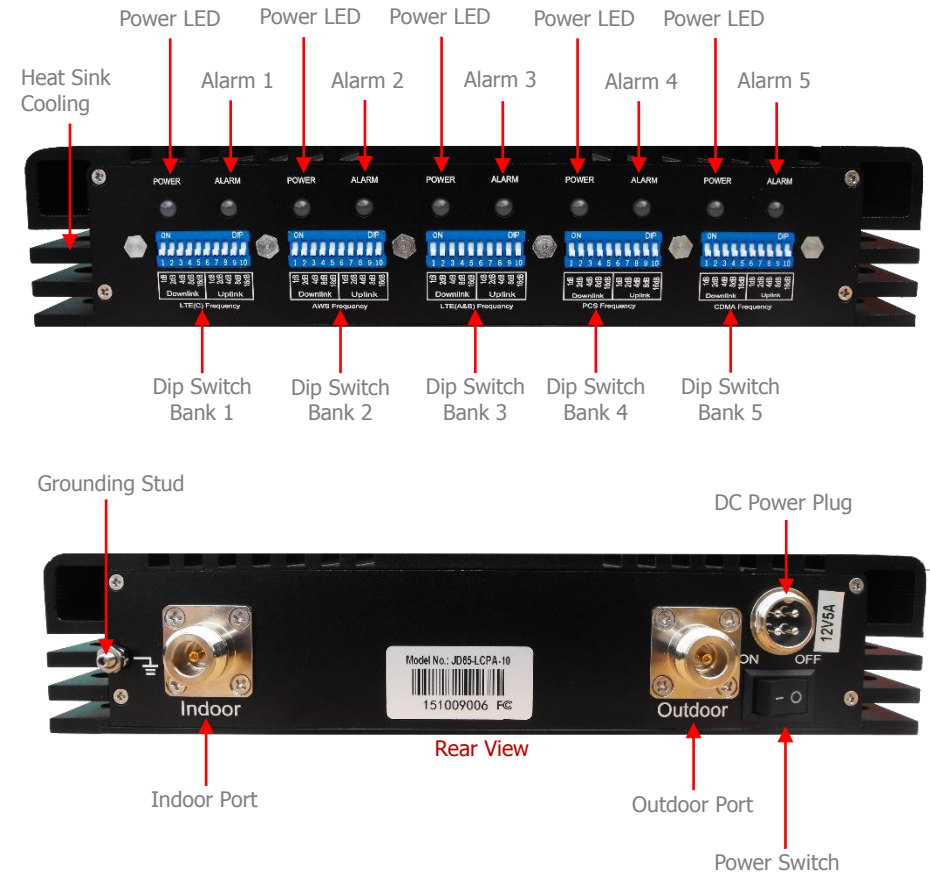

### 3. Installation

1. The repeater's main function is to improve weak RF signals to an area.
2. Selecting the appropriate accessories that are compatible with the frequency of the repeater is very important for optimal system performance. A700MHz Repeater needs to be used with accessories that supports the 700MHz band. In the same way, choosing accessories in the 1900MHz Band needs to go with a 1900MHz Repeater etc. For multi-band repeaters, please ensure the peripheral components used supports all the frequencies needed.
3. The signal strength at the outdoor antenna directly affects the efficiency of the indoor coverage. Therefore it is very important to choose the location of the outdoor antenna carefully. With this in mind, it is not recommended that the donor antenna be installed in an attic or at the side of a single or double story building.
4. The repeater is a two-way (full duplex) signal amplifier. Therefore there needs to be proper isolation between the outdoor antenna and indoor antenna in order to avoid signal oscillation of the repeater. (Feedback) There needs to be more than 15dB of isolation above the repeaters gain. For example, if the repeater gain is 60dB, then you need 75dB of isolation between outdoor antenna and indoor antenna.
5. The repeater gain is adjustable for both the uplink / downlink individually. Depending on the environment, the end-user may need to adjust the repeater gain to achieve optimum performance and desired coverage.
6. The repeater is designed to amplify the input signal, filter it and retransmit it to the desired area via service antennas. In order to reach the best performance, the outdoor signal should be better than -80dBm, and not over +10dBm. If the outdoor signal is very weak, then a pre-amplifier may be used.
7. Calculating the Link budget before setting the repeater gain.

#### Link budget calculation:

Outdoor signal strength – Loss of accessories (cable, connectors, splitters, Directional Couplers, Path Loss) + Antenna gain (outdoor antenna, indoor antenna) + Repeater gain = Indoor signal strength.

8. For all cellular applications, you need to use 50 Ohm rated coax. Besides affecting voice quality, using any other impedance of coax will put an extra load on your repeater and shorten its life span.

### 4.1 Optional Booster Antenna Kitting ~ Con't.

**Option 6:** 10dBi Outdoor Panel Antenna with 20 meters 400 Series Coax Cable (N-Male Connectors)

**Option 7:** 10dBi Log Periodic Antenna with 10 meters 5D-FB Coax Cable (N-Male Connectors)

Frequency	698~746	746~787	824~894	1850~1990	1710~2170
Antenna Gain (dBi)	10	10	10	10	10
Cable Loss (dB)	1.7	1.7	1.7	2.7	2.7
Final Gain Less	8.3	8.3	8.3	7.3	7.3

**Option 8:** 10dBi Outdoor Panel Antenna with 10 meters 400 Series Coax Cable (N-Male Connectors)

Frequency	698~746	746~787	824~894	1850~1990	1710~2170
Antenna Gain (dBi)	10	10	10	10	10
Cable Loss (dB)	1.3	1.3	1.3	2	2
Final Gain Less	8.7	8.7	8.7	8	8

**Option 9:** 10dBi Log Periodic Antenna with 5 meters 5D-FB Coax Cable (N-Male Connectors)

Frequency	698~746	746~787	824~894	1850~1990	1710~2170
Antenna Gain (dBi)	10	10	10	10	10
Cable Loss (dB)	0.8	0.8	0.8	1.4	1.4
Final Gain Less	9.2	9.2	9.2	8.6	8.6

**Option 10:** 10dBi Outdoor Panel Antenna with 5 meters 400 Series Coax Cable (N-Male Connectors)

Frequency	698~746	746~787	824~894	1850~1990	1710~2170
Antenna Gain (dBi)	10	10	10	10	10
Cable Loss (dB)	0.7	0.7	0.7	1	1
Final Gain Less	9.3	9.3	9.3	9	9



## 4. Optional Booster Antenna Kitting

The optional antenna kitting for model JDCR-LCPA Cellular Repeater are listed below for your reference.

**A:** The outdoor Antenna kit. There are 10 options with different type of antennas or variable cable length.

**Option1:** 10dBi Log Periodic Antenna with 30 meters 5D-FB Coax Cable (N-Male Connectors)

Frequency	698~746	746~787	824~894	1850~1990	1710~2170
Antenna Gain (dBi)	10	10	10	10	10
Cable Loss (dB)	5	5	5	8	8
Final Gain Less	5	5	5	2	2

**Option2:** 10dBi Log Periodic Antenna with 30 meters 400 Series Coax Cable (N-Male Connectors)

Frequency	698~746	746~787	824~894	1850~1990	1710~2170
Antenna Gain (dBi)	10	10	10	10	10
Cable Loss (dB)	3.8	3.8	3.8	6	6
Final Gain Less	6.2	6.2	6.2	4	4

**Option 3:** 10dBi Outdoor Panel Antenna with 30 meters 5D-FB Coax Cable (N-Male Connectors)

Frequency	698~746	746~787	824~894	1850~1990	1710~2170
Antenna Gain (dBi)	10	10	10	10	10
Cable Loss (dB)	5	5	5	8	8
Final Gain Less	5	5	5	2	2

**Option 4:** 10dBi Outdoor Panel Antenna with 30 meters 400 Series Coax Cable (N-Male Connectors)

Frequency	698~746	746~787	824~894	1850~1990	1710~2170
Antenna Gain (dBi)	10	10	10	10	10
Cable Loss (dB)	3.8	3.8	3.8	6	6
Final Gain Less	6.2	6.2	6.2	4	4

**Option 5:** 10dBi Log Periodic Antenna with 20 meters 5D-FB Coax Cable (N-Male Connectors)

Frequency	698~746	746~787	824~894	1850~1990	1710~2170
Antenna Gain (dBi)	10	10	10	10	10
Cable Loss (dB)	3.4	3.4	3.4	5.4	5.4
Final Gain Less	6.6	6.6	6.6	4.6	4.6

## 3.1 Installation Procedure

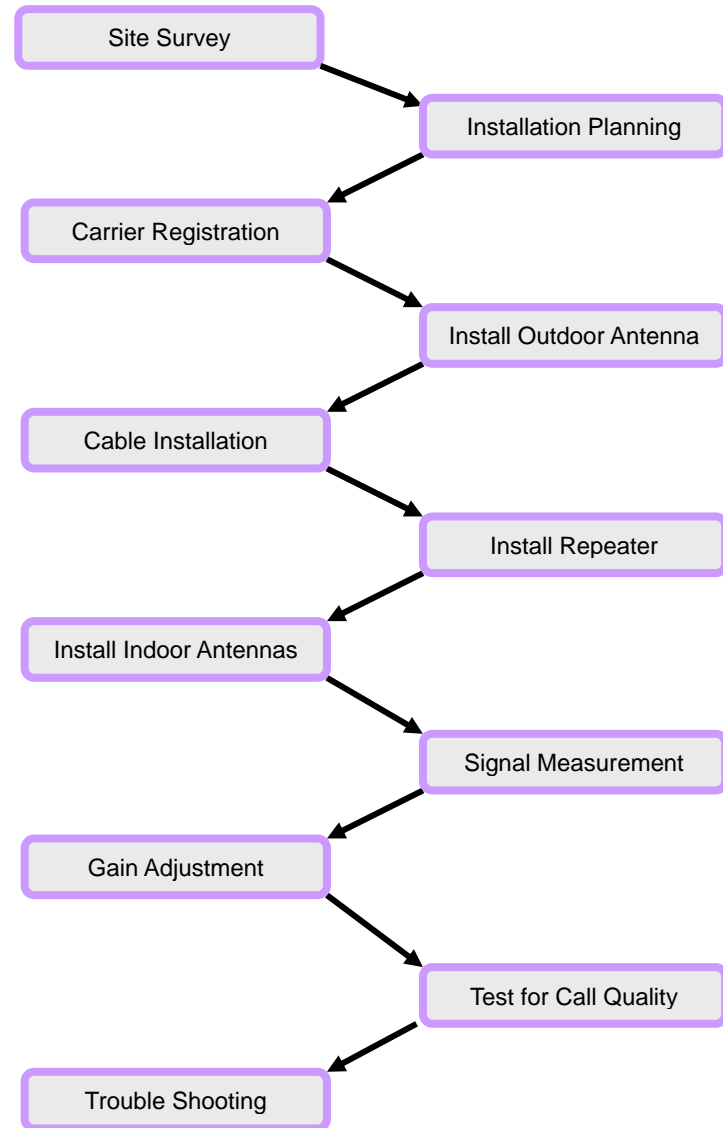

### 3.1 Installation Procedure – Cont.

- Check the contents supplied.
- Identify a suitable location where you would like to mount the donor antenna on your roof or at an elevated location, free of any other antennas or immediate obstructions. Confirm this location has the best input signal from the cell tower or towers you would like to support.
- Ensure the location is properly isolated from any of the indoor antennas and at the same time, ensure the cable length supplied is sufficient to complete your installation.
- Install the donor antenna and route the coax to the proposed location for the indoor base unit. **DO NOT COIL UP** any excess coax you may have which include service loops. These are detrimental to cellular performance.
- Connect the indoor service antennas, coax and power supply. Power up the unit and monitor the LED status for errors.
- If the donor antenna used is not an Omni-directional antenna or the nearest cell tower location is not known at the time of system commissioning, then you may need to rotate the donor antenna until the best signal strength or call quality is achieved on your mobile device inside the building, while making sure the LEDs stay green on the repeater.

*We suggest getting someone to help rotate the donor antenna while you monitor both your mobile device and the LEDs on the repeater at the same time.*

- If signal oscillation is between 1~4dB then the Alarm LED for the relevant band will turn amber. Please adjust the DL repeater gain till the LEDs turn green. (See attenuation adjustment)
- If the signal oscillation is between 10-15dB then the Alarm LED for the relevant band will turn red, and the respective circuit will then go into MUTE / Shutdown. This is as a result of not having enough isolation between the donor and service antennas or the input signal at the donor antenna is too strong. In this case attenuate the DL gain on the repeater and then match the UL gain to the same gain value. After each gain adjustment is made, quickly power cycle the repeater to ensure you are not trying to optimize the repeater while your ACG is active. (See attenuation settings for adjustments)

### 3.5 Troubleshooting

#### Q1. Why is there still no signal after installing the equipment?

##### Answer:

1. Check the power on repeater and power supply.
2. Check the connector of outdoor antenna is tight or not.
3. Check the connectors of RF cable are tight or not.
4. Check the outdoor signal is strong enough or not.
5. Check to make sure the antenna is installed correctly.
6. Check the connector of indoor antenna is tight or not.
7. Check the cable type is suitable or not.

#### Q2. Why the signal strength is too weak on the edge of area?

##### Answer:

1. Check the outdoor signal and antenna direction.
2. Check repeater is full gain or not.
3. Check all of the connectors are tight.
4. Change the location of outdoor/indoor antenna.
5. Check the cable type is suitable or not.
6. Deploy more indoor antennas.

#### Q3. Why can't I make a call after installation, even though I can detect a signal?

##### Answer:

1. Check LED status of repeater to make sure alarms are green.
2. Change the location of outdoor/indoor antenna.
3. Reduce the UL gain of the repeater.

#### Q4. The signal is not stable after turning on the repeater power.

##### Answer:

1. Check to see if the outdoor signal is stable or not.
2. Check the location of the donor antenna. Too close to other antennas.
3. Check the RF cable is broken or not and has no coils.
4. Confirm direction of donor antenna in relation to cell tower.

#### Q5. Why is the LED on the front of the repeater not lit?

##### Answer:

1. Check the power source is normal or not.
2. MUTE feature is active. Attenuate gain of repeater and cycle power.

### 3.4 Testing

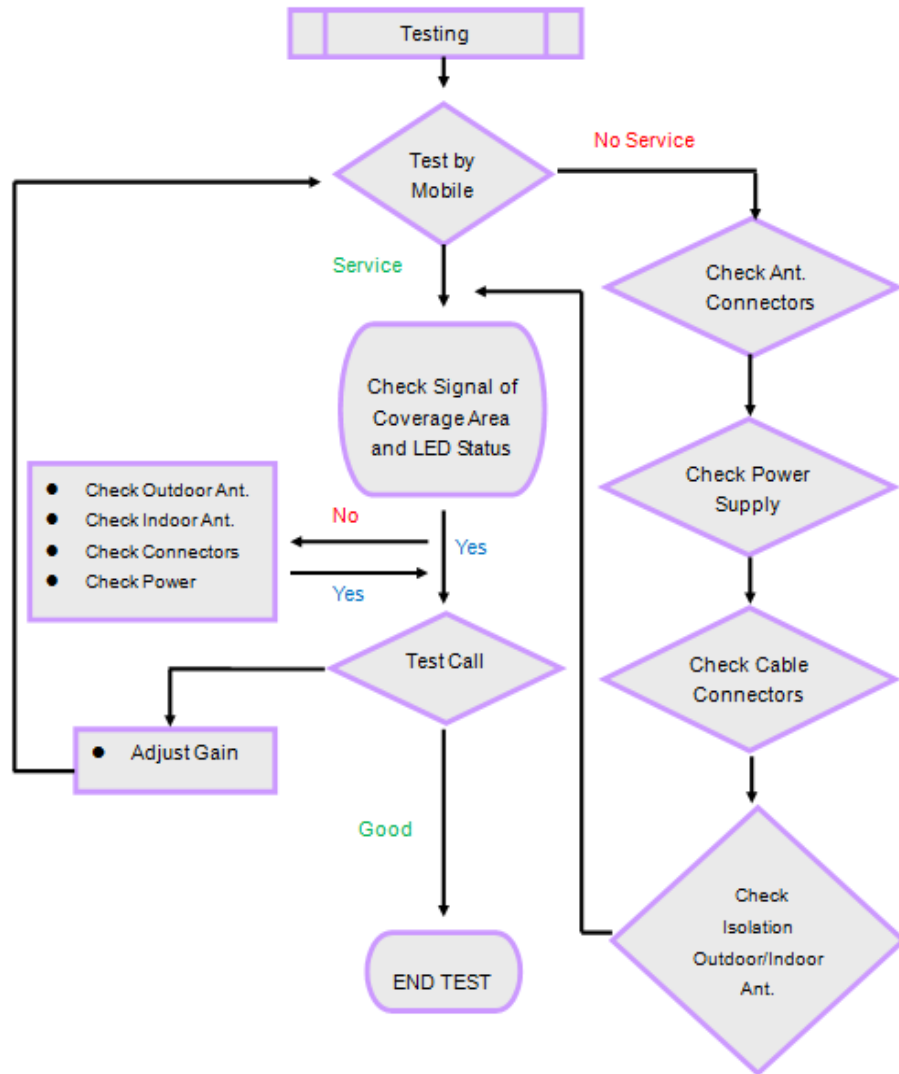

### 3.2 Antenna Installation and Coax Cable Wiring

We do not recommend installing the donor antenna of your repeater system in the attic or at the side of a single or double story building. Doing so will greatly reduce the quality of the input signal from the cell tower. Also you increase the risk of signal oscillation occurring thus having to attenuate the output power of your repeater which reduces the coverage area.



- Do not install the donor antenna near high voltage power lines.
- Please take the necessary safety measures when working on heights.
- Do not mount near or in the path of other antennas or satellite dishes.

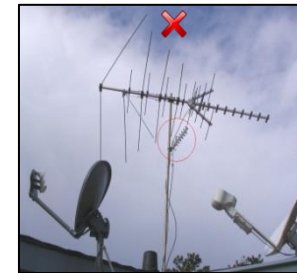

It is recommended that you mount your donor antenna in a spot that is free of any immediate obstructions. Making use of a pole or mounting bracket is recommended for optimum antenna performance.

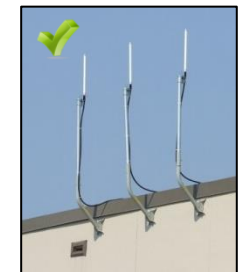

### 3.3 Manual Gain Adjustment ~ UL / DL

In order to meet and maintain safe environmental conditions for seamless network integration, this repeater is equipped with a dip switch assembly that allows you to manually control the Uplink / Downlink gain individually. The UL/DL attenuator control range is from 0dB to -31dB by 1dB increments in each band. There is a dip switch bank available for each frequency.

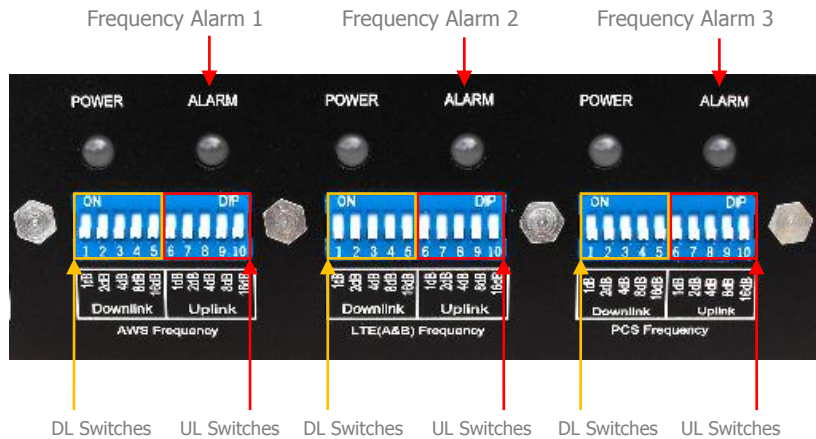

The DIP Switch control method is described as below.  
Switches 1-5 represents DL adjustment & 6-10 represents UL adjustment.

The default of UL/DL gain attenuator is at 0dB. (Full Power)

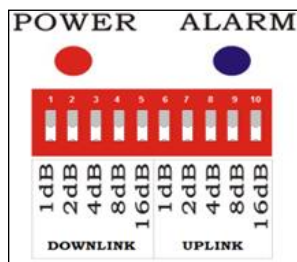

Example of the DL & UL Attenuated by 4dB

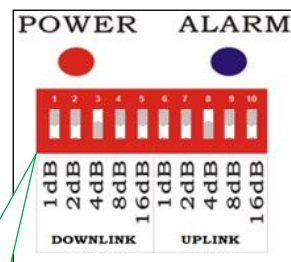

Note Switch Positions

### 3.3 Manual Gain Adjustment ~ UL / DL – Con't.

#### When do you adjust the Repeater Gain?

This repeater is equipped with an alarm feature that monitors the input gain. If the input gain is too high, the DL Alarm LED will change color from green to either amber or red indicating the intensity of the error. High input gain can occur if the donor antenna is in a location where the receive signal strength (RSSI) from the cell tower is extremely good (-50dB or better) or if signal oscillation is taking place. Signal Oscillation is when the amplified signal from the indoor service antenna is being received back into the donor antenna outside.

To determine what is the cause of your Alarm LED changing color you can disconnect the indoor antenna / service line from the "INDOOR" port of the repeater while the repeater is on. If the LED does not change to green, then your input signal from the cell tower is very strong. At this point you attenuate the DL gain by 1dB increments till the LEDs turns green again. Then you must match the same attenuation value to the UL set of switches.

Since this repeater is equipped with an AGC function, it is important to determine if at the time you are adjusting your DIP switches, the AGC has not already been activated. To determine this, quickly power cycle the repeater (OFF then Back ON) after you have made a switch adjustment. If any of the Alarm LED's take at least 10 sec to turn green, then AGC has been activated. At this point you want to add a little more attenuation to the respective circuit then power cycle the unit again. The aim is to have your LED's all green within 5 sec of the repeater being turned on. After which you can connect the indoor antenna / service line again.

If after reconnecting the indoor antenna or service line, the LED changes back to amber or red then signal oscillation is taking place. This is the result of your **indoor** and **outdoor** antennas being too close to each other and should therefore have more separation or continue to add more attenuation.

When complete, try making some test calls throughout the desired area of coverage while monitoring the LEDs to see if it changes color. If you are showing strong signal strength but your calls are not going through, it could be that you need to attenuate your uplink gain a bit more. Keep in mind however that you do not want to have more than a 5dB difference between the uplink and downlink values for optimum system performance.

We encourage you to call us if you are experiencing difficulty when commissioning your repeater system. We want to make sure you have seamless integration to the cellular network and optimal system performance. We are always happy to help. **1-866-4-JDTECK (53-8325)**.