

Abbreviations2

Safety2

1. Preface 3

2. Introduction / Features & Functions5

3. Installation7

3.1 Installation Procedure8

3.1 Installation Procedure . Cond9

3.2 Antenna Installing and Cable Wiring10

3.3 Manual Gain Adjustment - UL / DL11

3.4 Testing14







3.5 Trouble Shooting15

Specifications16

FCC Statement18

Terminology	Meaning
BTS	Base Transmitting Station
CDMA	Code Division Multiple Access
DL	Downlink
GSM	Global System for Mobile Communications
iDEN	Integrated Digital Enhanced Network
MS	Mobile Station
PCS	Personal Communication System
RF	Radio Frequency signals
UL	Uplink (<i>Communication channel from mobile device to cell tower</i>)
DL	Downlink (<i>Communication channel from cell tower to mobile device</i>)
Donor	Outdoor Antenna
LED	Light Emitting Diode

User Warnings – MUST READ!

- 
 1. This repeater must ONLY be used for the purpose it was intended for. Making any alternations to the design layout without first consulting with a trained technician can result in interference to the operator's network and liability by the end user.
- 
 2. Please read this entire manual carefully before using this product!
- 
 3. Only the power supply that came with the repeater should be used at all times. It is highly recommended that the repeater is grounded and lightning protection used.
- 
 4. Do not attempt to open any part of the repeater. This will void the warranty and can cause an electric shock. Electrostatic can also cause damage to the internal components.
- 
 5. Please keep away from any heating-equipment, because the repeater will dissipate heat when working. Do not cover the repeater with anything that influences heat-dissipation.
- 
 6. Do not place or mount the repeater in a location that is exposed to the elements. This will void the warranty and can cause an electric shock.

1. Preface

Nowadays, personal mobile communication is developing at a very rapid rate and persons are having higher expectations and demands on the mobile communication network. A high-speed and high-capacity communication network has become the trend of future development. At present second-generation (2G) mobile communication systems like GSM is widely used all over the world, but mostly in developing nations, whereas third-generation (3G) and forth-generation (4G) mobile communication technology is widely used in Europe, North America and Korea.

For example, Code Division Multiple Access (CDMA) technology is used which greatly extends the signal width -- the so-called spread spectrum modulation. As an advanced wireless communication technology, it features good multi-channel access capability, anti-multipath fading capacity, anti-narrowband interference capability and security protection capabilities.

The CDMA network has, what is called a "cell breathing effect". That is, the coverage will gradually shrink as the cell load increases. The cell breathing effect makes network planning more complicated. The CDMA technology itself determines that the load of the network at the early stage of construction should be higher than that of the GSM network. Therefore, adding carriers and roaming agreements between them is a major means of expanding network capacity, and adding BTS or Node B base stations is an auxiliary means of capacity expansion. The aim of the radio network should to provide continuous coverage, instead of hotspot coverage.

The cost of wireless repeaters are relatively low and the construction is simple. They have the functions of a mini BTS or Node B. On the network, repeaters can help a BTS or Node B to achieve the optimal network quality at a minimum cost.

A cellular tower typically supports a large capacity of users but is affected by a relatively small coverage footprint. Therefore, the number of users who can access it is limited and a large amount of channel resources are wasted. The best way of solving this problem is to use repeaters to extend the BTS coverage to fully utilize the telecommunication resources. For example, in cellular network construction in Asia, repeaters are no longer considered as peripheral devices to cover blind areas in the network but as part of the core network itself.

The complete coverage is not only a prerequisite for a high quality mobile cellular network, but also a factor that attracts users. From this point of view, a network operator should first consider providing a radio network with a complete coverage. The seamless coverage in urban areas, heavy traffic areas, office buildings, super markets, and top grade hotels is the first step to consummate the network.

In such a background, JDTECK has successfully developed advanced repeaters that are applicable to any mobile network and indoor distributed antenna system. (DAS) Repeaters are available to support any technology or frequency used today.

Because a large amount of BTS or Node B devices are deployed in densely populated urban areas, there is usually no large blind area. Repeaters are simply used to cover small blind areas and provide signal coverage inside buildings or sub-ground locations. Typically, radio frequency (RF) repeaters are used when optical fibers are not available in buildings or when using a fiber solution is not cost effective.

Since the number of repeaters on a cellular network usually increases with the number of buildings to be covered in a specific sector, multiple repeaters may end up feeding from one BTS or Node B. In view of this, only low powered repeaters (below 1 W) should be deployed in densely populated areas.

Repeaters adopt an integrated module concept. It is compact in structure and combines the RF module and the monitoring mode in one unit. Owing to its high selectivity, stability and reliability, repeaters are widely applied to indoor signal distribution in small areas such as office buildings, meeting rooms, hotels, tea shops, night clubs, and cafes where signals are shielded. They are also used to cover shadow areas outdoors. Such repeaters are very suitable to signal optimization in densely populated urban areas.

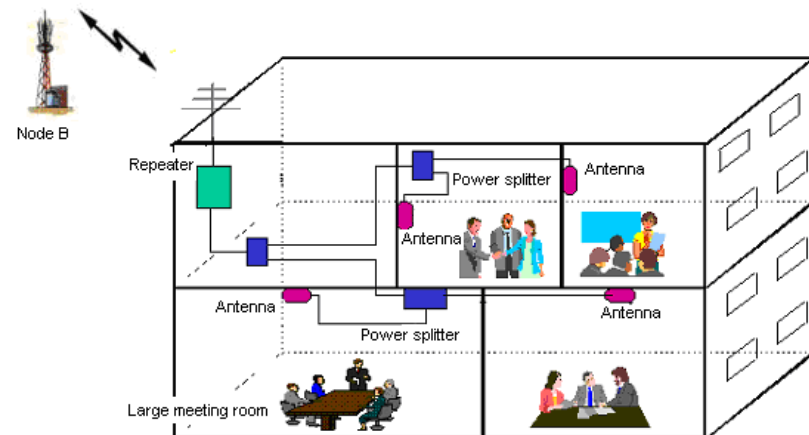

Figure 1 shows the applications of the repeaters.

2. Introduction

This full duplex mobile communications repeater from JDTECK is the perfect solution for providing a wireless improvement in the cellular reception of a home, office, restaurant, VIP Room, apartment, building or shopping mall, in the quickest time possible.

It is designed to improve the call quality of an area by receiving, amplifying and re-transmitting signals of the base station into a specified area via the service antenna of the repeater.

To maintain safe and specific output signal levels, this repeater has a built-in signal oscillation detection circuit with color changing LEDs to indicate its environmental status. The Alarm LEDs located on the front of the unit (Alarm Low & Alarm High) will change color from green to orange or red, (depending on the intensity) if the system detects signal oscillation in either band or, if the input signal is beyond a safe limit so as to avoid interference to the cellular network.

This repeater also has an automatic gain control (AGC) feature that will reduce the output power of the repeater if oscillation is detected. This range can vary from 15-20dB depending on the model of your repeater. If the range of the AGC is less than the value of the gain the repeater needs to be reduced by, then the end user can make use of yet another feature of manual gain control to further reduce the gain by using the dip switches to manually attenuate (reduce) the repeater's output gain of either the uplink or downlink individually.

JDTECK's repeaters also feature a Network Safe / MUTE feature that automatically shuts off the transmission side of the repeater to protect the cellular network if no adjustments are made to eliminate alarm readings on the repeater's LEDs. You will want to make sure the LEDs remain green at all times for optimum system performance.

The main cause of signal oscillation is when the indoor antenna is too close in proximity to the outdoor antenna on the roof.

Alarm LED status chart and recommended action:

Green - System functioning well.

Orange - Slight detection of Oscillation.

Red - Strong Signal Oscillation.

Off . Repeater is not transmitting (MUTE Activated)

Features & Functions

- ✓ Sleek attractive housing.
- ✓ LED indicators to monitor environmental status.
- ✓ Supports all technologies including, GPRS, EDGE, HSDPA & UMTS.
- ✓ Low power consumption.
- ✓ ALC function. (Auto Limit Control)
- ✓ AGC function. (Automatic Gain Control)
- ✓ MGC function. (Manual Gain Control)
- ✓ MUTE function. (Shuts down if no change in environmental conditions)
- ✓ Heat Sink cooling fins to dissipate heat quickly and efficiently



3. Installation

1. The repeater's main function is to improve weak RF signals to an area.
2. Selecting the appropriate accessories that are compatible with the frequency of the repeater is very important for optimal system performance. An 850MHz Repeater needs to be used with accessories that supports the 850MHz band. In the same way, choosing accessories in the 1900MHz Band needs to go with a 1900MHz Repeater etc. For dual band or multi-band repeaters, please ensure the peripheral components used supports all the frequencies needed.
3. The signal strength from the outdoor antenna directly affects the efficiency of the indoor coverage. It is very important to choose the location of the outdoor antenna carefully. With this in mind, it is not recommended that the donor antenna be installed in an attic.
4. The repeater is a two-way (full duplex) signal amplifier. Therefore there needs to be proper isolation between the outdoor antenna and indoor antenna in order to avoid signal oscillation on the repeater. (Interference) There needs to be more than 15dB of isolation above the repeater gain. For example, if the repeater gain is 60dB, then you need 75dB of isolation between outdoor antenna and indoor antenna.
5. The equipment is gain adjustable for both the uplink / downlink. Depending on the environment the end-user may need to adjust the gain to achieve optimum performance.
6. The equipment is designed to amplify the outdoor signal to indoor coverage. In order to reach the best performance, the outdoor signal should be greater than -80dBm, and not over +10dBm. If the outdoor signal is very weak, then a pre-amplifier may be used.
7. Calculating the Link budget before setting a repeater gain.

Link budget calculation:

Outdoor signal strength . Loss of accessories (cable, connector, splitters)
+ Antenna gain (outdoor antenna, indoor antenna) + Repeater gain =
Indoor signal strength

8. For all cellular applications, you need to use 50 Ohm coax. Besides affecting the system performance, using any other impedance of coax will put an extra load on your repeater and shorten its life span.

3.1 Installation Procedure

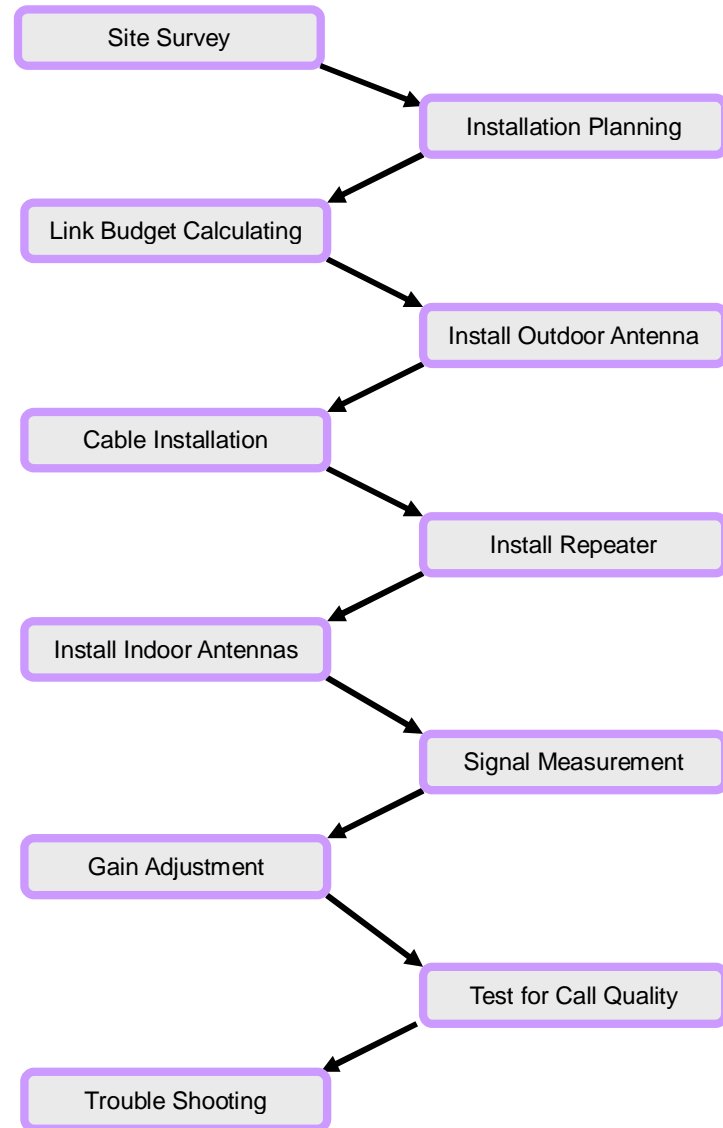

3.1 Installation Procedure – Cont.

- Check the contents supplied.
- Identify a suitable location where you would like to mount the donor antenna on your roof. Confirm this location has the best input signal from the cell tower.
- Ensure the location is properly isolated from the indoor antenna and at the same time, ensure the cable length supplied is sufficient to complete your installation.
- Install the donor antenna and route the coax to the proposed location for the indoor base unit. **DO NOT COIL UP** any excess coax you may have.
- Connect the indoor service antennas, coax and power supply. Power up the unit and monitor the LED status for errors.
- Rotate the donor antenna until the best signal strength or call quality is achieved on your mobile device, while making sure the LEDs stay green on the repeater.

We suggest getting someone to help rotate the donor antenna while you monitor both your mobile device (Phone or PC Card) and the LEDs on the repeater at the same time.

- If signal oscillation is between 1~4dB then the Alarm LED for the relevant band will turn orange. Please adjust the dip switches till the LEDs turn green. (See dip switch adjustment)
- If the signal oscillation is between 15-18dB then the Alarm LED for the relevant band will turn red, and the repeater will then shut down. This is as a result of not having enough isolation between the donor and service antennas. In this case attenuate the dip switches on the repeater. (See dip switch settings for adjustments)

3.2 Antenna Installing and Cable Wiring

We do not recommend installing the donor antenna of your repeater system in the attic or at the side of a single story building. Doing so will reduce the quality of the input signal from the cell tower. Also you increase the risk of signal oscillation taking place, thus having to attenuate the output power of your.



- Do not install the donor antenna near high voltage power lines.
- Please take the necessary safety measures when working on heights.
- Do not mount near or in the path of other antennas or satellite dishes.



It is recommended that you mount your donor antenna in a spot that is free of any immediate obstructions. Making use of a pole or mounting bracket is recommended for optimum antenna performance.



3.3 Manual Gain Adjustment ~ UL / DL

In order to meet safe environmental requirements for seamless network integration, this repeater is equipped with a dip switch assembly that allows you to manually control the Uplink / Downlink gain individually. The UL / DL attenuator control range is from 0dB to -15dB by 5dB increments.



System default is 0dB Attenuation (Full Power) unless supplied with a pre-amp.

Depending on the frequency band of your repeater, it will determine the dip switches you will need to adjust and the corresponding LED that will show the status of the adjustments made.

(DL1 & UL1 . Alarm Low) . For 800 & 900 MHz Band
 (DL2 & UL2 . Alarm High) . For 1700, 1800, 1900 & 2100 MHz Band

Turn **ON** the dip switches to reduce power as follows:

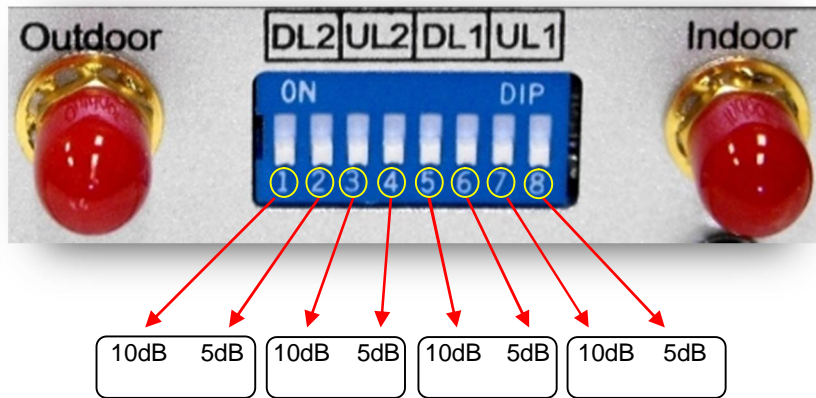

Put **ON** a pair of switches for a total of 15dB reduction in gain.

3.3 Manual Gain Adjustment ~ UL / DL – Con't.



N.B. . Before you make any dip switch adjustments in order to get both Alarm LEDs (High & Low) showing green, it is recommended you first try to increase the distance between the indoor unit and the donor antenna. This will ensure you get the maximum power output of the repeater. If you have already done this or relocating the indoor unit is not possible or convenient, then your next adjustment would be to reduce the downlink power (DL1 or DL2) of the repeater, starting with the lesser value first. In most cases, after these adjustments are made, this would usually be enough to get the Alarm LED to show green.

Color Changing Alarm LEDs

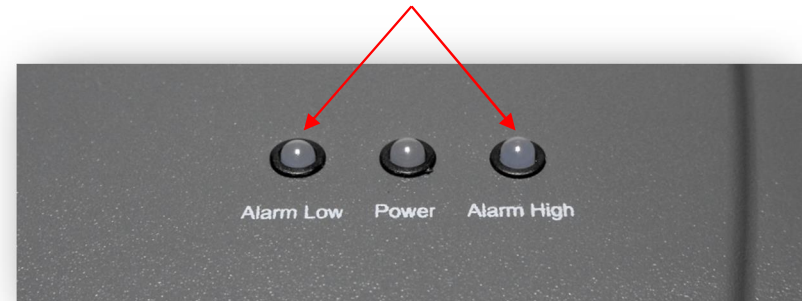

How does this Alarm Feature work?

The alarm feature your repeater is equipped with monitors the input gain. If the input gain is too high, the Alarm LED will change color from green to either, orange or red indicating the intensity of the error. High input gain can occur if the donor antenna is in a location where the receive signal strength from the cell tower is extremely good (-50 or better) or if signal oscillation is taking place. Signal Oscillation is when the amplified signal from the indoor service antenna is feeding back to the donor antenna outside.

To determine what is the cause of your Alarm LED changing color you can disconnect the indoor antenna / service line from the indoor port of the repeater. If the LED does not change to green, then your input signal from the cell tower is very strong and you need to attenuate (Turn ON) the DL DIP Switches till the LEDs turns green again. Then you must match the same attenuation value to the UL, after which you can connect the indoor antenna / service line again.

3.3 Manual Gain Adjustment ~ UL / DL – Con't.

If after connecting back the indoor antenna or service line, the LED changes back to amber or red then signal oscillation is taking place. This is the result of your indoor and outdoor antennas being too close to each other and should be separated more. You could also attenuate the DL DIP Switches by 1dB increments till the LEDs turn green again then you must match the same attenuation value to UL DIP switches.

Try making some test calls throughout the desired area of coverage while monitoring the LEDs to see if it changes color. If you are showing strong signal strength but your calls are not going through, it could be that you need to attenuate your Uplink a bit more. Keep in mind however that you do not want to have more than a 5dB difference between the uplink and downlink values for optimum system performance.

We encourage you to call us when commissioning your repeater system to make sure you have seamless integration to the cellular network. We are always happy to help. **1-866-4-JDTECK (53-8325)**.

3.4 Testing

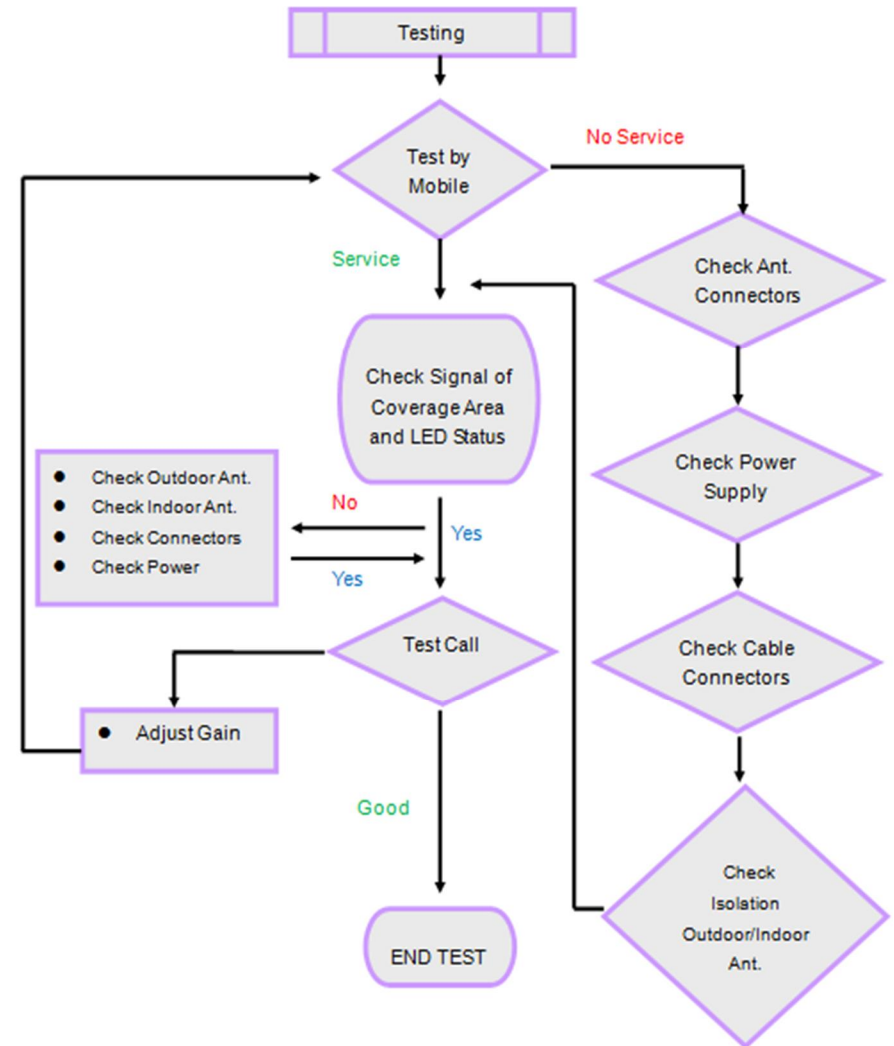

3.5 Troubleshooting

Q1. Why is there still no signal after installing the equipment?

Answer:

1. Check the power on repeater and power supply.
2. Check the connector of outdoor antenna is tight or not.
3. Check the connectors of RF cable are tight or not.
4. Check the outdoor signal is strong enough or not.
5. Check to make sure the antenna is installed correctly.
6. Check the connector of indoor antenna is tight or not.
7. Check the cable type is suitable or not.

Q2. Why the signal strength is too weak on the edge of area?

Answer:

1. Check the outdoor signal and antenna direction.
2. Check repeater is full gain or not.
3. Check all of the connectors are tight.
4. Change the location of outdoor/indoor antenna.
5. Check the cable type is suitable or not.
6. Deploy more indoor antennas.

Q3. Why can't I make a call after installation, even though I can detect a signal?

Answer:

1. Check LED status of repeater to make sure alarms are green.
2. Change the location of outdoor / indoor antenna.
3. Reduce the repeater gain.

Q4. The signal is not stable after turning on the repeater power.

Answer:

1. Check to see if the outdoor signal is stable or not.
2. Check the location of the donor antenna. Too close to other antennas.
3. Check the RF cable is broken or not.
4. Confirm direction of donor antenna in relation to cell tower.

Q5. Why is the LED on the front of the repeater not lit?

Answer:

1. Check the power source is normal or not.
2. MUTE feature is active. Attenuate gain of repeater and cycle power.

Mechanical Specifications

Input / Output Port	SMA - Female
Impedance	50 Ω
Dimensions (W x D x H)	183 x 126 x 48mm
Weight	~1.5Kg (5.5Lbs)
Operating Temperature	-10°C ~ 50°C
Environment Conditions	IP40
Switching Adapter	Input AC 90~265V, Output DC 9V / 3A

Frequency Specifications

Model	JD55-PR
FCC ID	SQX-JD55-PR
CE	CE1177!
Filter Bandwidth	GSM & CDMA 25MHz PCS 50MHz DCS 75MHz WCDMA 60MHz
Max total output power	Downlink ~ 10dBm Uplink ~ 5dBm
Max. Gain	Downlink ~ 55dB Uplink ~ 55dB
Gain Flatness	CDMA & GSM: ~5dB, PCS & DCS: ~8dB WCDMA ~5dB
AGC Range	~ 15dB
Maximum Input Power	0dBm
Gain Control Range (MGC)	~ 15dB in 5dB step
V.S.W.R	~2
Inter-modulation Products	9KHz~1GHz ~36dBm 1GHz~12.75GHz ~30dBm
Spurious Emission	9KHz~1GHz ~36dBm 1GHz~12.75GHz ~30dBm
Spurious Emission Mask	Complies with 3GPP TS 25.106
Modulation Accuracy	Complies with 3GPP TS 25.106
Peak Code Domain Error	Complies with 3GPP TS 25.106
Frequency Stability	~0.01ppm
ACPR	~ 30dB @ ±5MHz & ±10MHz
Noise Figure (@ max gain)	~5dB
Group Delay	~0.5 micro Sec

Model Specifications

Classification	Bandwidth Range (MHz)
A. Frequency Range CDMA / TDMA / AMPS / GSM 850 PCS / CDMA / GSM / GPRS 800Mhz	DL - 869-894 UL - 824-849
B. Frequency Range (GSM / DCS) 900Mhz	DL - 935-960 UL - 890-915
C. Frequency Range (GSM / WCDMA / UMTS) 1800Mhz	DL - 1805-1880 UL - 1710-1785
D. Frequency Range CDMA / TDMA / AMPS / GSM 850 PCS / CDMA / GSM / GPRS 1900Mhz	DL - 1930-1990 UL - 1850-1910
E. Frequency Range (WCDMA / UMTS) 2100Mhz	DL - 2110-2170 UL - 1920-1980
F. Frequency Range CDMA / TDMA / AMPS / GSM 850 PCS / CDMA / GSM / GPRS 800 / 1900Mhz	DL - 869-894 / 1930-1990 UL - 824-849 / 1850-1910
G. Frequency Range (GSM / DCS) 900 / 1800Mhz	DL - 935-960 / 1805-1880 UL - 890-915 / 1710-1785
H. Frequency Range (GSM / WCDMA / UMTS) 900 / 2100Mhz	DL - 935-960 / 2110-2170 UL - 890-915 / 1920-1980
I. Frequency Range (GSM / WCDMA / UMTS) 1700 / 2100Mhz	DL - 2110-2155 UL - 1710-1755
J. Frequency Range (Cellular / AWS) 800 / 1700 / 2100Mhz	DL - 869-894 / 2110-2155 UL - 824-849 / 1710-1755

FCC Statement

PLEASE NOTE: It is normal for your repeater to be quite warm while in use.

Note: This equipment has been tested and found to comply with the limits for a Class B digital device, pursuant to part 15 of the FCC Rules. These limits are designed to provide reasonable protection against harmful interference in a residential installation. This equipment generates, uses and can radiate radio frequency energy and, if not installed and used in accordance with the instructions, may cause harmful interference to radio communications. However, there is no guarantee that interference will not occur in a particular installation. If this equipment does cause harmful interference to radio or television reception, which can be determined by turning the equipment off and on, the user is encouraged to try to correct the interference by one or more of the following measures:

- ~ Reorient or relocate the receiving antenna.
 - ~ Increase the separation between the equipment and receiver.
 - ~ Connect the equipment into an outlet on a circuit different from that to which the receiver is connected.
 - ~ Consult the dealer or an experienced radio/TV technician for help.
- The antenna used for the transmitter must not be connected to, or operating in conjunction with any other antenna or transmitter.
Modifications not expressly approved by JDTECK could void the user's authority to operate the equipment under FCC rules.